

Instructions for Eco-eye Elite and Mini

1. Overview

Eco-eye consists of a sensor, transmitter and receiver/display unit. The sensor clips around the incoming supply cable, usually at the meter, and monitors the total current passing through it. This is done by the user without disturbing or cutting any wiring and without the need for a qualified electrician. The sensor plugs into the transmitter unit and the information is sent wirelessly to the receiver unit which translates it into meaningful information - Kilowatts, Cost or CO2 emissions.

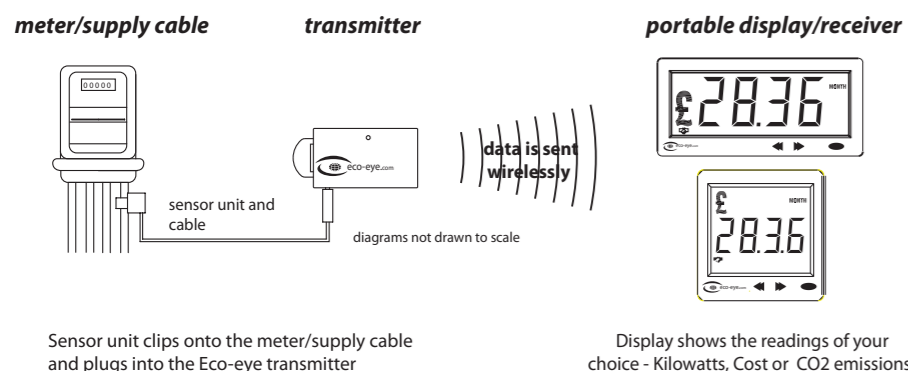

Live electricity cable tester (shown right)

Supplied to ensure that the sensor is clipped around the correct electricity cable. The LED should light up if you have located the live electricity cable. **Remove the tester once you have located the correct cable and plug the sensor cable into the transmitter.**

Note - No harm will be done to Eco-eye or to the electricity supply if the sensor is inadvertently fitted around an incorrect cable.

2. The Sensor

The standard sensor is of a two part construction and clips around any live cable up to 13mm in diameter. Typically this will be found on the far right of the meter and coloured or marked with red or brown. If the meter is situated remotely or in an external box, the sensor can either be fitted onto the cable at the meter or inside the property where it enters the fuse board. The latter is preferable in order to minimise signal loss.

NOTE 1: THE SENSOR UNIT MAY BUZZ ESPECIALLY WHEN NOT CONNECTED TO THE TRANSMITTER. THIS IS PERFECTLY NORMAL.

NOTE 2: ECO-EYE WILL ONLY WORK WITH INDIVIDUAL CABLES (I.E. NOT MULTI-CORE CABLES) AND IS THEREFORE NOT INTENDED FOR THE DIRECT MONITORING OF INDIVIDUAL APPLIANCES.

NOTE 3: DO NOT FORCE THE CLIP TO CLOSE AROUND A CABLE WHICH IS TOO LARGE. IT IS ESSENTIAL THAT THE FACES OF THE SENSOR ON BOTH SIDES OF THE CLIP MAKE CONTACT WITH EACH OTHER. IT IS ACCEPTABLE FOR THE SENSOR TO BE A LOOSE FIT AROUND THE CABLE. ALTERNATIVE - SIZED SENSORS ARE AVAILABLE ON REQUEST.

Standard Size

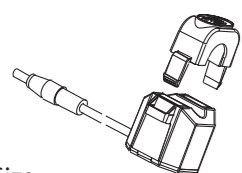

- Suitable for cables up to 13mm in diameter.
- Press the sides to separate the two parts. Click shut when round cable.

Larger Size

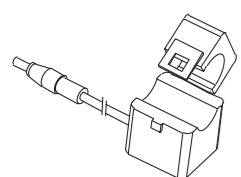

- Suitable for cables up to 16mm in diameter.
- This unit is hinged - Pull the catch to open. Click shut when round cable.

3. The Transmitter Unit

Press the release catch to remove the wall plate from the transmitter and using the two self-adhesive pads (supplied) or screws (not supplied) affix in a convenient position close to the cable being monitored. Ensure the release catch is positioned to the left side.

Fit 2 x AA batteries into the transmitter ensuring the correct orientation and polarity (see below). The LED should initially flash twice (brightly) and then emit a regular 4 second low intensity flash.

NOTE: THE RED LED LIGHT FLASHING EVERY 4 SECONDS INDICATES THAT THE WIRELESS SIGNAL IS TRANSMITTING CORRECTLY. A SOLID LIGHT INDICATES AN IRREGULARITY HAS BEEN DETECTED. IN THIS SITUATION, REMOVE THE BATTERIES AND RECOMMENCE THE START UP PROCEDURE.

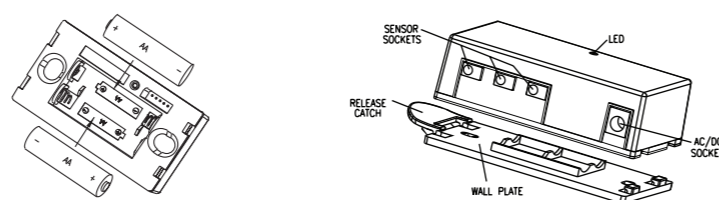

The transmitter can accept up to three sensors and is suitable for monitoring single, multi-phase or split-source supplies. (additional sensors required).

ONLY NOW SHOULD YOU FIT BATTERIES TO THE RECEIVER UNIT

4. Receiver/Display Unit - Elite or Mini

Remove the battery cover and insert 2 x AA batteries, ensuring correct polarity. (See figs 1 and 2 below). Replace the battery cover. The unit goes through a power-up routine whereby it is possible to change certain parameters (currency symbol, voltage etc. - see Section 10). If the sensor and transmitter units are connected correctly, the Eco-eye receiver will automatically display the current KW reading. A handshake icon will also become visible at the bottom left hand side of the screen and 'blink' every time an incoming signal is received.

NOTE: ALL ECO-EYE UNITS CAN BE POWERED WITH THE OPTIONAL AC/CD MAINS ADAPTORS. THE SOCKET FOR THE TRANSMITTER IS LOCATED ADJACENT TO THE SENSOR SOCKET. THE SOCKET FOR THE MINI DISPLAY IS ON THE SIDE OF THE UNIT AND THE SOCKET FOR THE ELITE IS LOCATED UNDER THE BATTERY COVER.

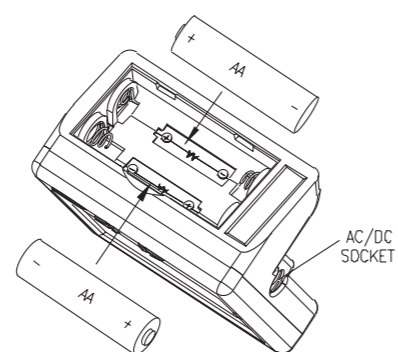

Fig. 1 - Eco-eye Mini underside showing battery compartment

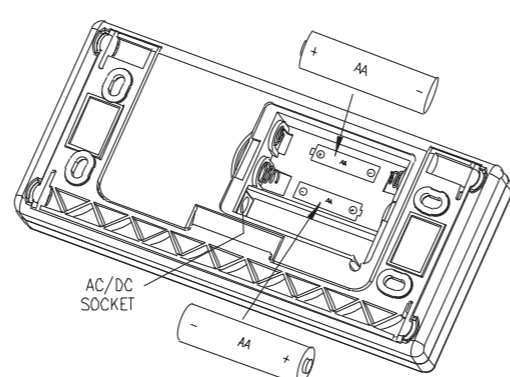

Fig. 2 - Eco-eye Elite reverse showing battery compartment

5. Elite Mounting Options

Free-standing option: Release catches at B (see fig. 1) and gently pull out the hinged stand until it clicks into the open position. Eco-eye can then be used on a table, desk or other flat surface (as in fig. 2).

Wall-mounted option: Release catches at A and B (see fig. 1) and gently remove the mounting frame. Fit the mounting frame to the wall in the required position using the adhesive pads (supplied) or screws. Present Eco-eye squarely to the mounting frame until catches A and B are lined up and can latch into position. (See fig. 3)

Alternative wall-mounting option: Once fitted as above, Eco-eye can also be pivoted forward (see fig.4) until a 'click' is felt. This option is ideal for mounting your unit at a higher level on the wall. NOTE: Eco-eye must be returned to the standard wall mounting position before it can be removed from the mounting frame.

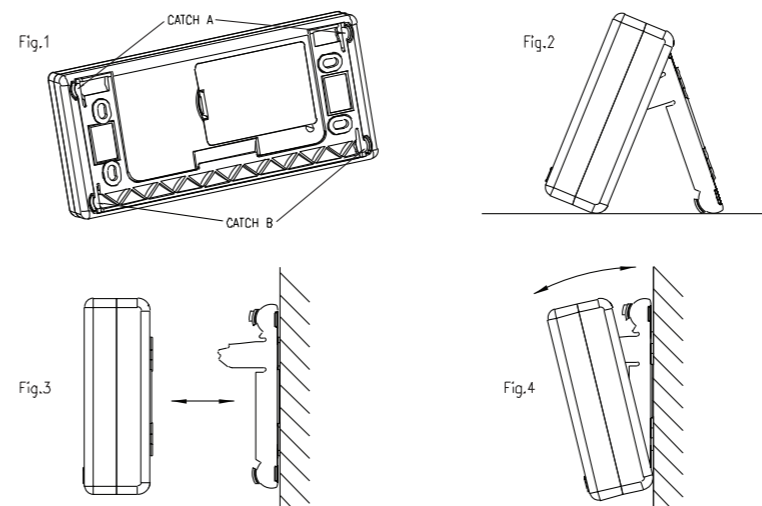

6. Programming Cost and Time

Eco-eye needs to know the time and the unit cost of your electricity in order to provide you with the correct information.

(a) Press and hold the OVAL BUTTON A for 3 - 5 seconds. On release the default currency symbol (£, \$ or €), 'KW' icon and 'SET MODE' icons will be displayed together with flashing numerals which can be adjusted to your own electricity tariff using the + and - ARROW KEYS.

NOTE: THE DISPLAY IS TO 3 DECIMAL PLACES FOR GREATER ACCURACY. I.E. 10.5 PENCE PER UNIT IS DISPLAYED AS £0.105.

**Remember: 1 kW = 1000 watts,
1000 watts for 1 hour duration = one kWh
1 kWh = 1 unit of electrical energy**

(b) Press the OVAL BUTTON A again to enter the current time. The 'TIME' icon becomes visible and minute numerals will flash. Use the + and - ARROW KEYS to set the minutes.

(c) Press the OVAL BUTTON A again to activate the HOUR numerals. Use + and - ARROW KEYS to set the hours in 24 hour format.

(d) Press the OVAL BUTTON A to return to normal display mode and save changes.

NOTE: 10 SECONDS OF INACTIVITY IN SET MODE WILL RETURN THE UNIT TO NORMAL DISPLAY MODE, WITHOUT SAVING CHANGES.

7. Operation

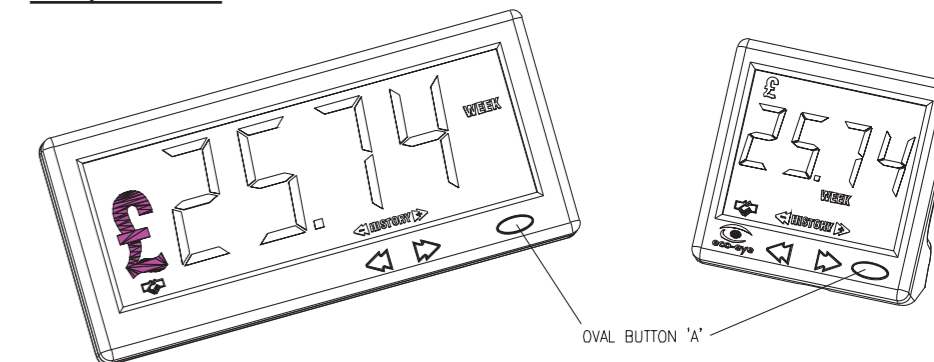

The operation of the Eco-eye receiver/display unit for real-time USAGE is controlled solely by the OVAL BUTTON A.

From the initial KW usage screen:

- Press the OVAL BUTTON A once to show the 'COST PER HOUR' mode.
- Press the OVAL BUTTON A again to show the 'COST PER DAY' mode.
- Press the OVAL BUTTON A again to show the 'COST PER WEEK' mode.
- Press the OVAL BUTTON A again to show the 'COST PER MONTH' mode.
- Press the OVAL BUTTON A again to show the 'COST PER YEAR' mode.
- Press the OVAL BUTTON A again to show the 'KG CO₂' mode. This displays the amount of CO₂ which will be discharged into the atmosphere per month based on your CURRENT usage.
- Press the OVAL BUTTON A again to show the current time.
- Press the OVAL BUTTON A once more to return to KW consumption mode.

8. Historical Data

Whilst you are in the real-time modes (listed in 7. operation) you are able to recall historical data related to that mode. For example, if you are displaying COST PER DAY, you can look at the individual costs for the last 32 days.

The 'HISTORY' icon flashes when historical data is on the display.

(a) Pressing the - ARROW KEY once will take you to the ACCUMULATED history mode and will display the actual amount/cost already consumed in the current period. e.g - Current hour or day, etc.

(b) Pressing the - ARROW KEY again will display '-01' whilst the key is depressed and upon release the value displayed will be the actual amount/cost of usage in the '-01' selected time period. Pressing the key again will display '-02' etc.

(c) Pressing the Oval Button A at any time returns the unit to real-time operation.

NOTE: THE MEMORY IN YEAR MODE CAN BE RESET AT ANY POINT BY SIMPLY PRESSING AND HOLDING THE OVAL BUTTON A FOR 15 SECONDS AT WHICH POINT ' - - - - ' WILL BE DISPLAYED. THIS DATA CAN BE VIEWED AT ANY POINT BY FOLLOWING THE INSTRUCTIONS AT (A) ABOVE. THIS IS PARTICULARLY USEFUL IF YOU WISH TO MEASURE THE COST OF YOUR CONSUMPTION OVER A SPECIFIC PERIOD OF TIME.